

A SICHERHEITSHINWEISE SAFETY ADVICES

B MONTAGE, PFLEGE UND WARTUNG ASSEMBLY, CARE INSTRUCTIONS, SERVICE AND MAINTENANCE

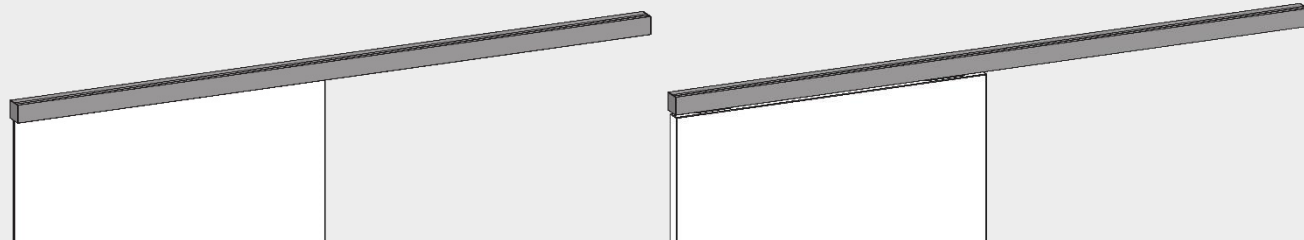

A Sicherheitshinweise

D

Wichtige Sicherheitshinweise für die Montage und Nutzung von Schiebetürsystemen:

(Zusätzlich zu Montage- und Bedienungsanleitung zu beachten, um Schäden an Produkt sowie Personen- und Sachschäden zu vermeiden.)

Wichtig: Alle Nutzer sind über die sie betreffenden Punkte der nachfolgenden Hinweise sowie die Hinweise aus Montage- bzw. Bedienungsanleitung zu informieren!

Allgemein:

- Schiebetüren dürfen nicht zu hart zu- oder aufgezo-gen werden. Dies trifft vor allem auf Schiebetüren ohne Softeinzug zu.

Montage:

- Mitgeliefertes Befestigungsmaterial ist auf Kompatibilität mit den vorhandenen Untergründen zu prüfen. Gegebenenfalls muss geeignetes Befestigungsmaterial selbst besorgt werden.
- Vor der Montage müssen die Klemmflächen mit fettlösenden Haushaltsmitteln von Fetten befreit werden.
- Es besteht die Gefahr von Quetschungen beim Heben der Tür. Entsprechend ist erforderliche Schutzkleidung zu tragen.

B Montage, Pflege und Wartung

Wichtige Informationen allgemein:

- Maximal zulässiges Gewicht der Tür liegt bei 40kg.
- Mindest- und Maximalbreiten je nach Ausführung beachten
- Mindest- und Maximal-Türdicken je nach Ausführung beachten
- Mitgeliefertes Befestigungsmaterial ist auf Kompatibilität zu den vorhandenen Untergründen zu prüfen. Gegebenenfalls muss geeignetes Befestigungsmaterial selbst besorgt werden.
- Softeinzug nicht ölen oder anderweitig schmieren.

safety advices

GB

Important safety-related information for the mounting and use of sliding door systems:

(Follow these instructions in addition to the mounting and operating instructions in order to avoid damage of product and damage to person or property.)

Important: All users have to be informed about relevant points mentioned in following safety advices and installation and operating instructions!

General information:

- Do not shut sliding doors with excessive force. This is especially important on sliding doors without soft closing device.

Assembly:

- Included mounting material must be checked for compatibility with the existing wall and ceiling. If required, suitable mounting material must be purchased.
- Clean clamping areas with fat solvent (standard commercial cleaning agent) before mounting.
- There is a danger of bruising when lifting the door. Wearing protective clothing is required.

Assembly, care instructions, service and maintenance

Important information:

- Maximum permissible weight of the door is 40kg.
- Note minimum and maximum widths depending on version
- Note minimum and maximum door thicknesses depending on the version
- Included mounting material must be checked for compatibility with the existing wall and ceiling. If needed, suitable mounting material must be purchased.
- Do not oil or otherwise lubricate the softstop unit

B

Wartung:

- Der Sitz und die Gängigkeit der geklemmten Teile sowie die Justierung der Tür müssen regelmäßig kontrolliert werden. Insbesondere im Falle von hochfrequentierten Anlagen sollte die Prüfung von einem Fach- oder Installationsbetrieb erfolgen.
- Beschädigte Glaselemente (Abplatzungen und/oder Ausmuschelungen) müssen unverzüglich ausgetauscht werden!
- Die Reinigung der Metall-Oberflächen (z.B. Griffe, Schiene) darf nur mit geeigneten Reinigern und Pflegemitteln erfolgen.

Pflege allgemein:

- Die Oberflächen der Schiebetürsysteme sind nicht wartungsfrei und sollten gemäß ihrer Ausführung gereinigt werden.
- Für metallische Oberflächen (Eloxal-/Edelstahloberfläche) bitte nur geeignete Reiniger ohne Scheuermittelanteil verwenden.
 - Für lackierte Oberflächen bitte nur entsprechende lösemittelfreie Reiniger verwenden.

Maintenance:

- Check clamped parts at regular intervals for proper positioning, smooth running and the door for correct adjustment. Especially highly frequented door systems require inspection by properly qualified staff (specialized companies or installation firms).
- Immediately replace damaged glass elements (glass flaking and/or conchoidal fractures)!
- Only use suitable cleaning and care products to clean the metallic surfaces (e.g. handles, rail).

General care instructions:

- The surface finishes of the sliding door systems are not maintenance-free and should be cleaned according to their material and texture.
- For metallic surfaces (anodized/stainless steel finish) please only use appropriate cleaning agents without abrasive additives.
 - For varnished surfaces please only use appropriate solvent-free cleaning agents.

Holztür / wooden door

Mindestbreite 850mm
Mindesttürdicke 28mm
Maximal Türdicke 40mm

Min. door width is 850mm
min. door thickness 28mm
Max door thickness 40mm

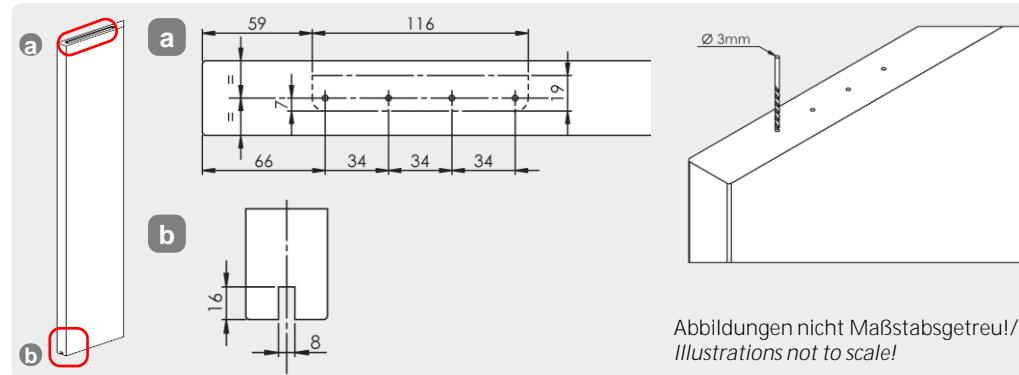
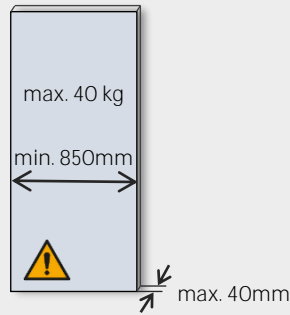

Abbildungen nicht Maßstabsgetreu!
Illustrations not to scale!

Glastür / glassdoor

Mindestbreite bis Standardtürhöhe 2058mm:
-> min. 750mm
2058mm - 2200mm:
-> min. 850mm

Min. door width up to standard door height 2058mm:
-> min. 750mm
2058mm - 2200mm:
-> min. 850mm



Klemm- und Klebebereiche
reinigen
clean clamping and adhesive
areas

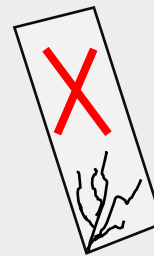

Scheibe ist vor
Beschädigung zu schützen
glass must be protected
from damage

Lieferumfang / scope of delivery

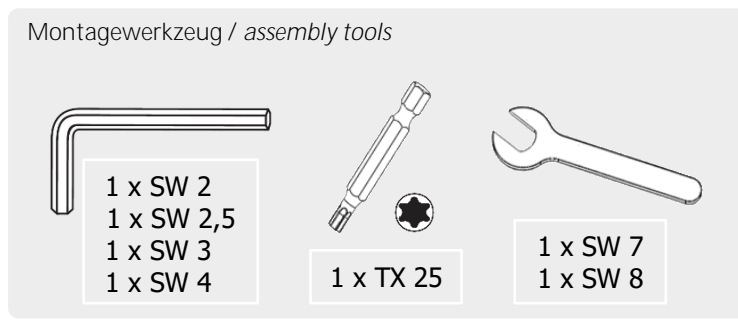
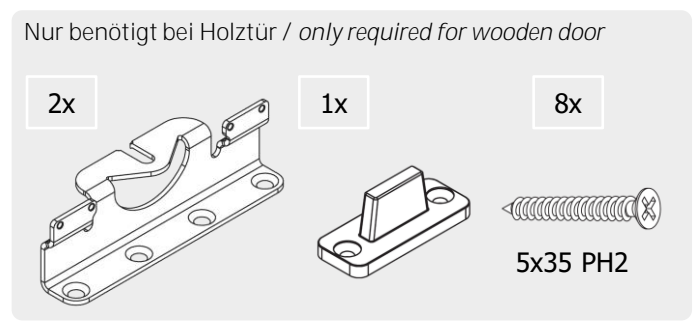
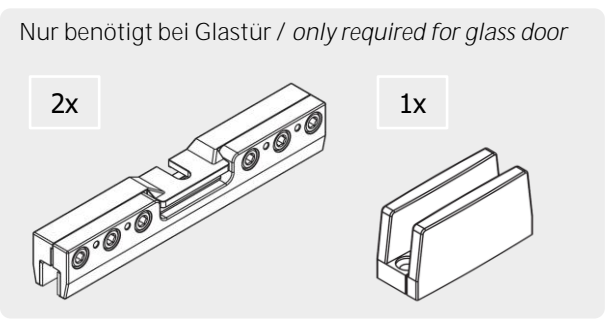
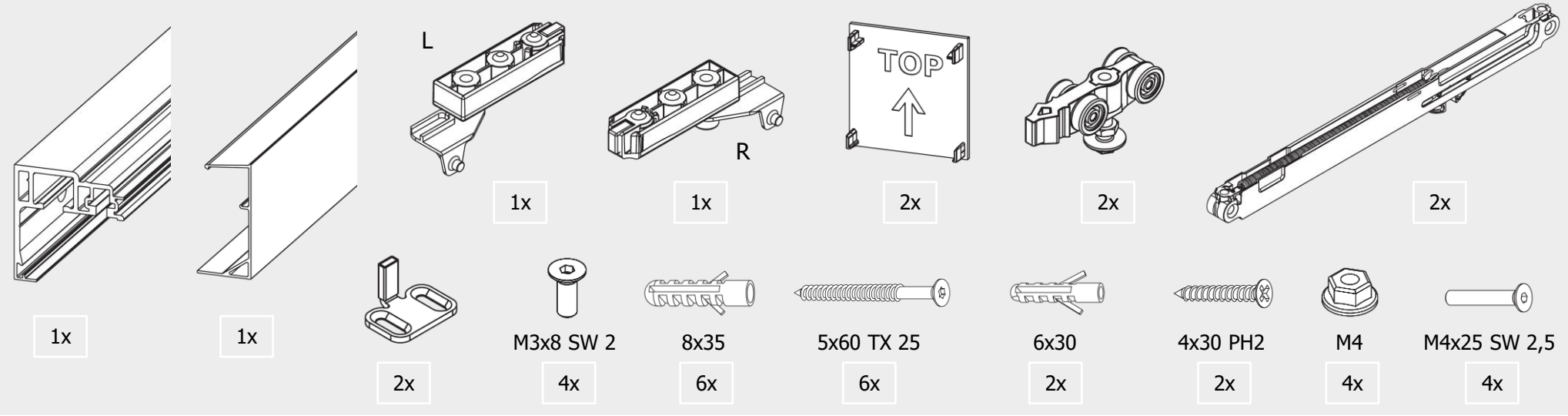

Montagewerkzeuge (nicht im Lieferumfang) / assembly tools (not included)

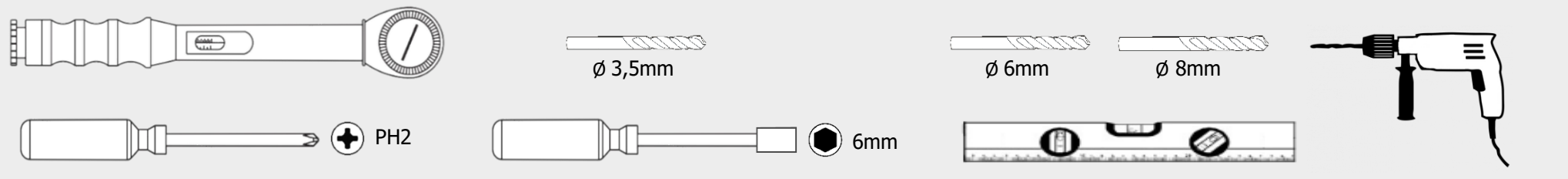

I Glastür /
glass door

Abbildungen nicht Maßstabsgetreu! / *Illustrations not to scale!*

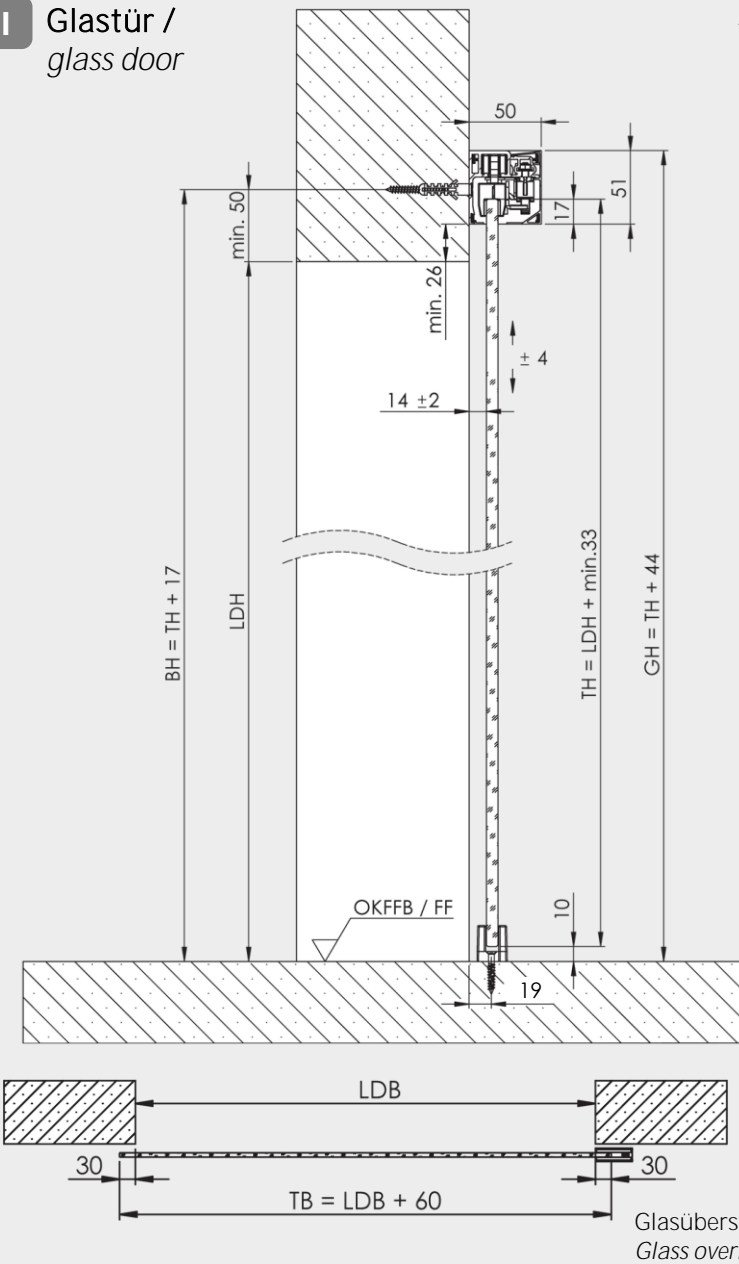

- BH = Bohrhöhe / *drilling level*
- GH = Gesamthöhe / *total height*
- TH = Türhöhe / *door height*
- TB = Türbreite / *door width*
- LDH = Lichte Durchgangshöhe / *pass line height*
- LDB = Lichte Durchgangsbreite / *pass line width*

Glasüberstand: 30mm empfohlen
Glass overlap: 30mm recommended

Distanzprofil-Set* (nicht im Lieferumfang)
Distance profile set (not included)*

Der Wandabstand kann mit optional erhältlichen Abstandsprofilen um 18,5mm erweitert werden.
The wall distance can be extended by 18.5mm with optionally available spacer profiles.

*Set enthält zusätzlich verlängerte Endkappen
**Set contains additional extended end caps*

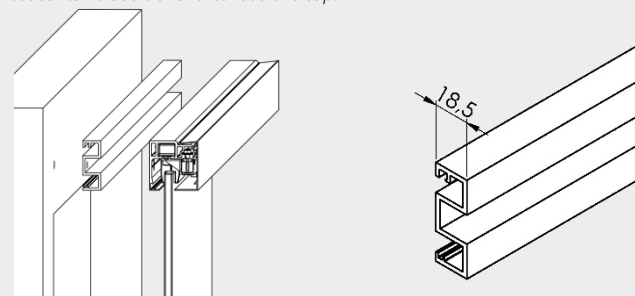

ohne Abstandsprofil
Without spacer profile

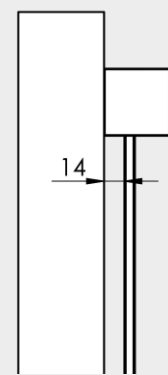

mit Abstandsprofil
With spacer profile

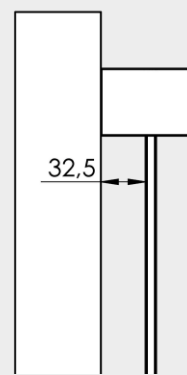

I Holztür /
wooden door

Abbildungen nicht Maßstabsgetreu! / Illustrations not to scale!

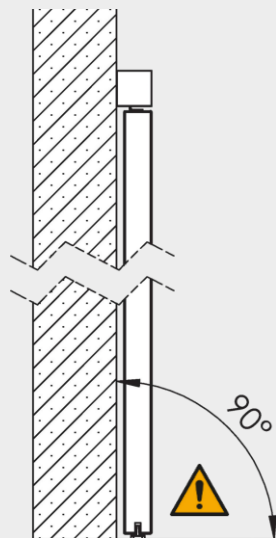
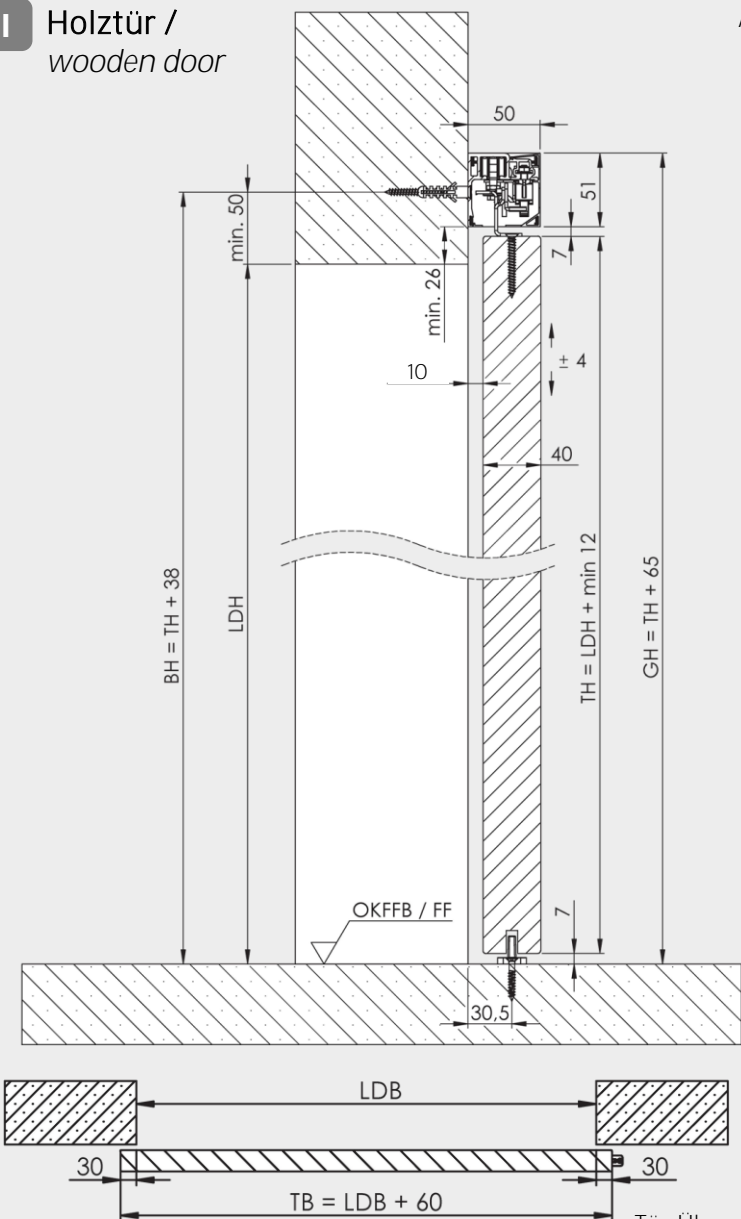

- BH = Bohrhöhe / drilling level
- GH = Gesamthöhe / total height
- TH = Türhöhe / door height
- TB = Türbreite / door width
- LDH = Lichte Durchgangshöhe / pass line height
- LDB = Lichte Durchgangsbreite / pass line width

Tür-Überstand: 30mm empfohlen
Door overlap: 30mm recommended

Distanzprofil-Set* (nicht im Lieferumfang)
Distance profile set* (not included)

Der Wandabstand kann mit optional erhältlichen Abstandsprofilen um 18,5mm erweitert werden.
The wall distance can be extended by 18.5mm with optionally available spacer profiles.

*Set enthält zusätzlich verlängerte Endkappen
*Set contains additional extended end caps

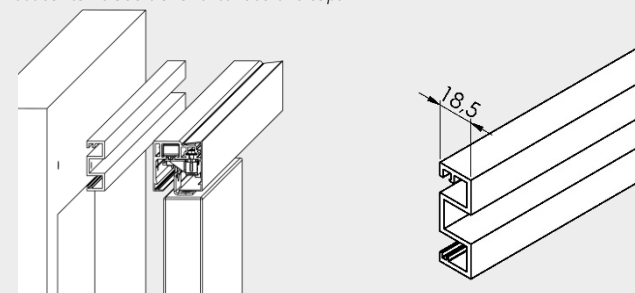

ohne Abstandsprofil
Without spacer profile

mit Abstandsprofil
With spacer profile

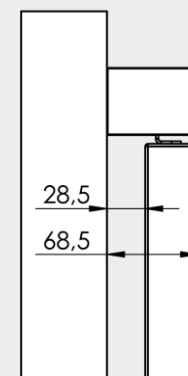
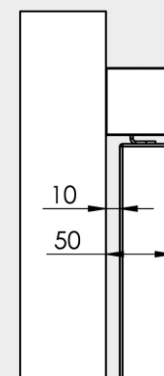

(Abstände bei Türstärke 40mm / distances for door thickness 40mm)

1

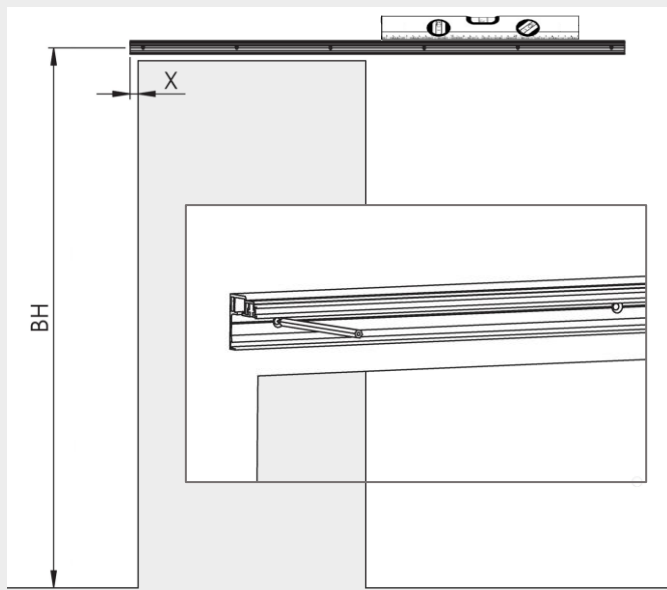

X = Glasüberstand / glass overlap + 4mm
 Empfohlen / recommended: X = 34mm

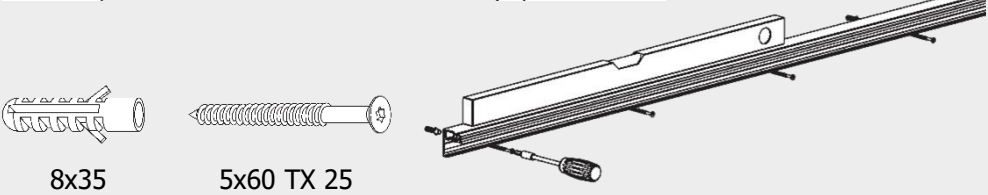
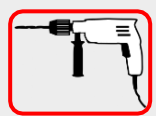
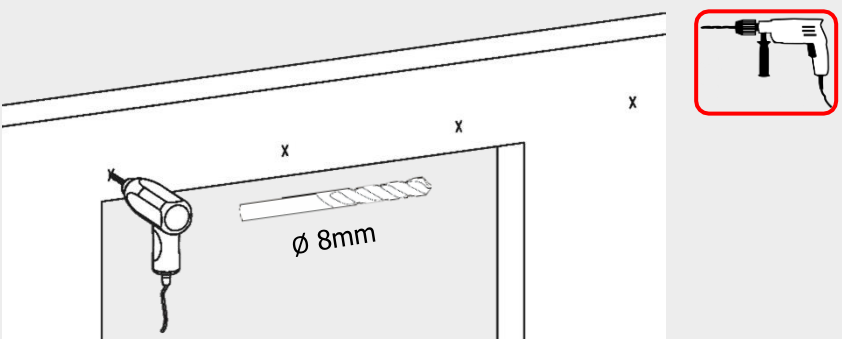

8x35

5x60 TX 25

2a

Glastür / glass door

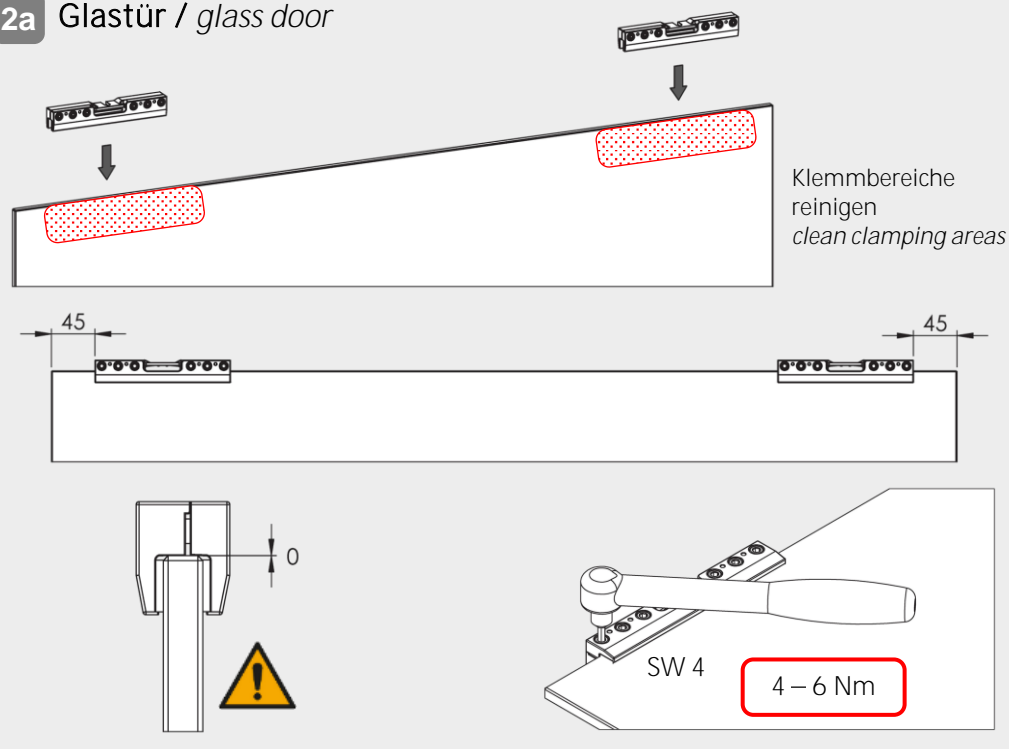

2b

Holztür / wooden door

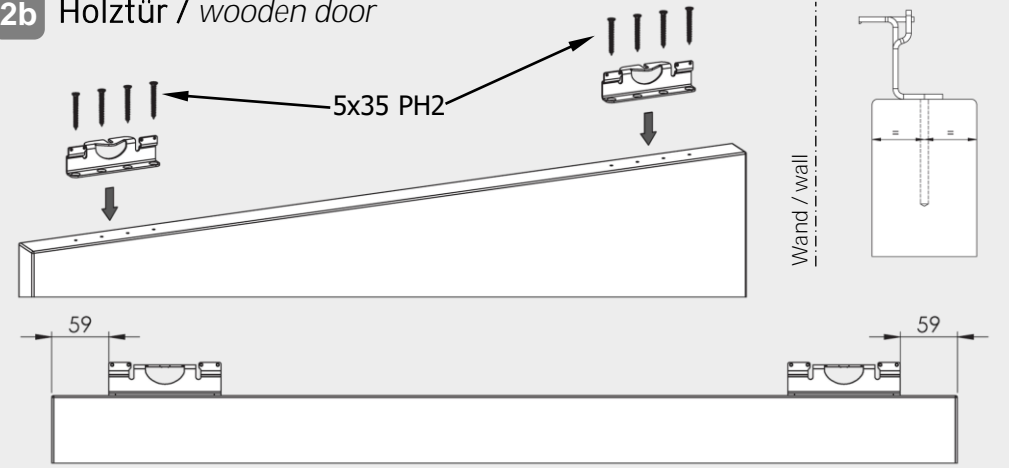

3 Bodenführung / floor guidance

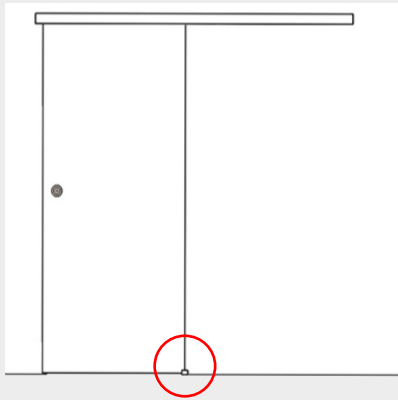

Glastür /
glass door

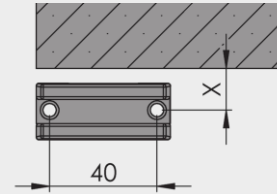
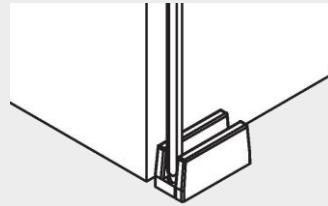

Ggf. zusätzlich das Maß des
Abstandsprofils addieren /
If applicable, add thickness
of spacer profile.

$X = 18,5 \pm 2$

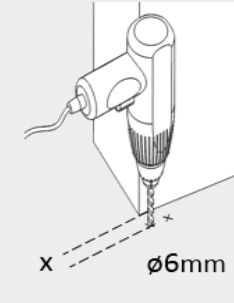

$X = 29,5$

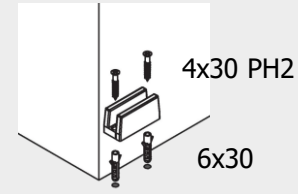

Holztür /
wooden door

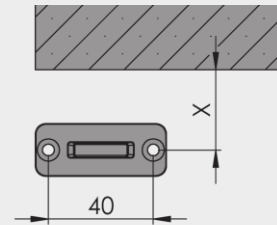
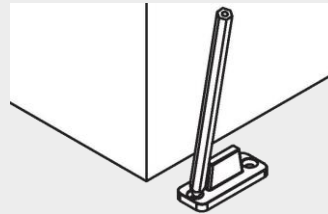

$\phi 6\text{mm}$

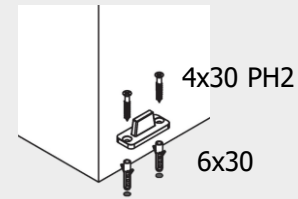

4

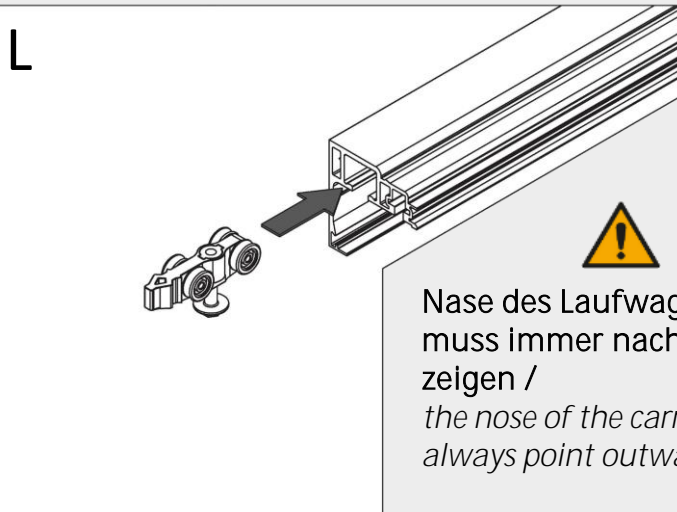
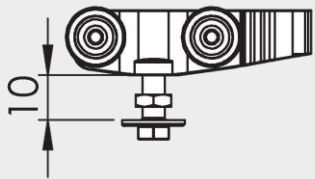

Nase des Laufwagens
muss immer nach außen
zeigen /
the nose of the carriage must
always point outwards

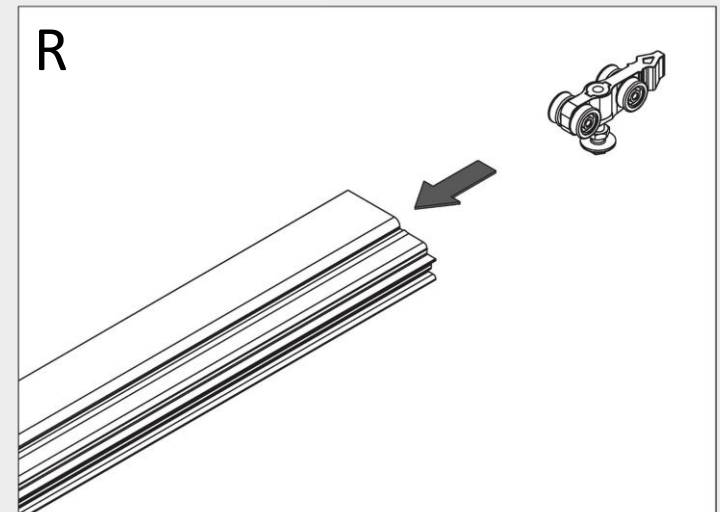

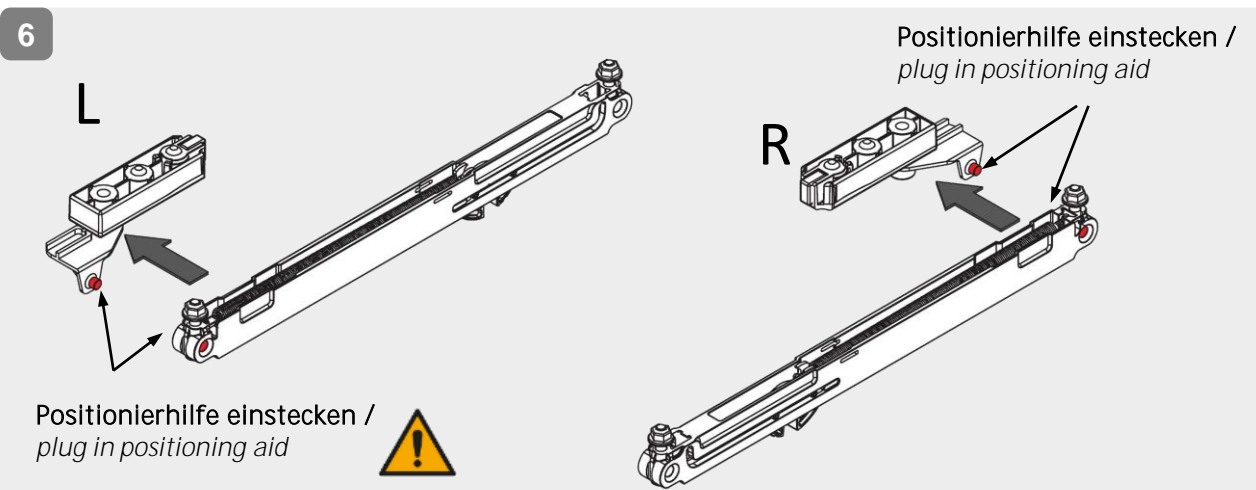
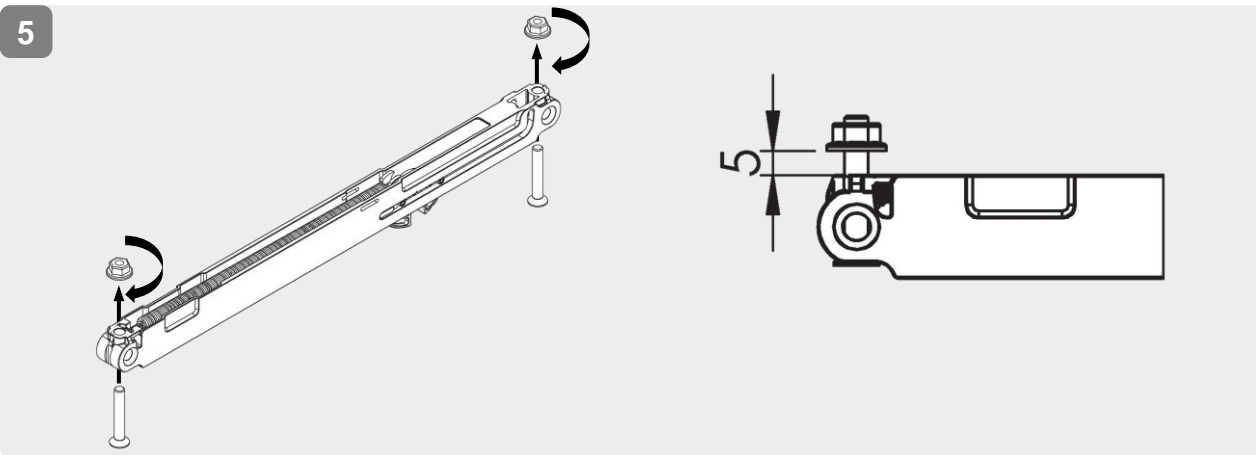

Bei der Montage des Softeinzuges ist strikt darauf zu achten, dass die Positionierhilfe mit dem Stopper fest verbunden ist, und dass der Zapfen der Positionierhilfe in der endseitigen Bohrung der Dämpfereinrichtung einsitzt, sodass in einer Endstellung des Türflügels der Dämpfer vollständig eingefahren ist.
 Nur hierdurch ist gewährleistet, dass eine Verletzung des Deutschen Teils des europäischen Patents EP 2678507 B1 vermieden wird. / when installing the Softclosing-unit is strictly to ensure that the positioning aid is firmly connected to the stopper, and that the pin of the positioning aid is seated in the end bore of the damper device, so that in an end position of the door of the damper is fully retracted.
 Only this ensures that a violation of the German part of the European patent EP 2678507 B1 is avoided.

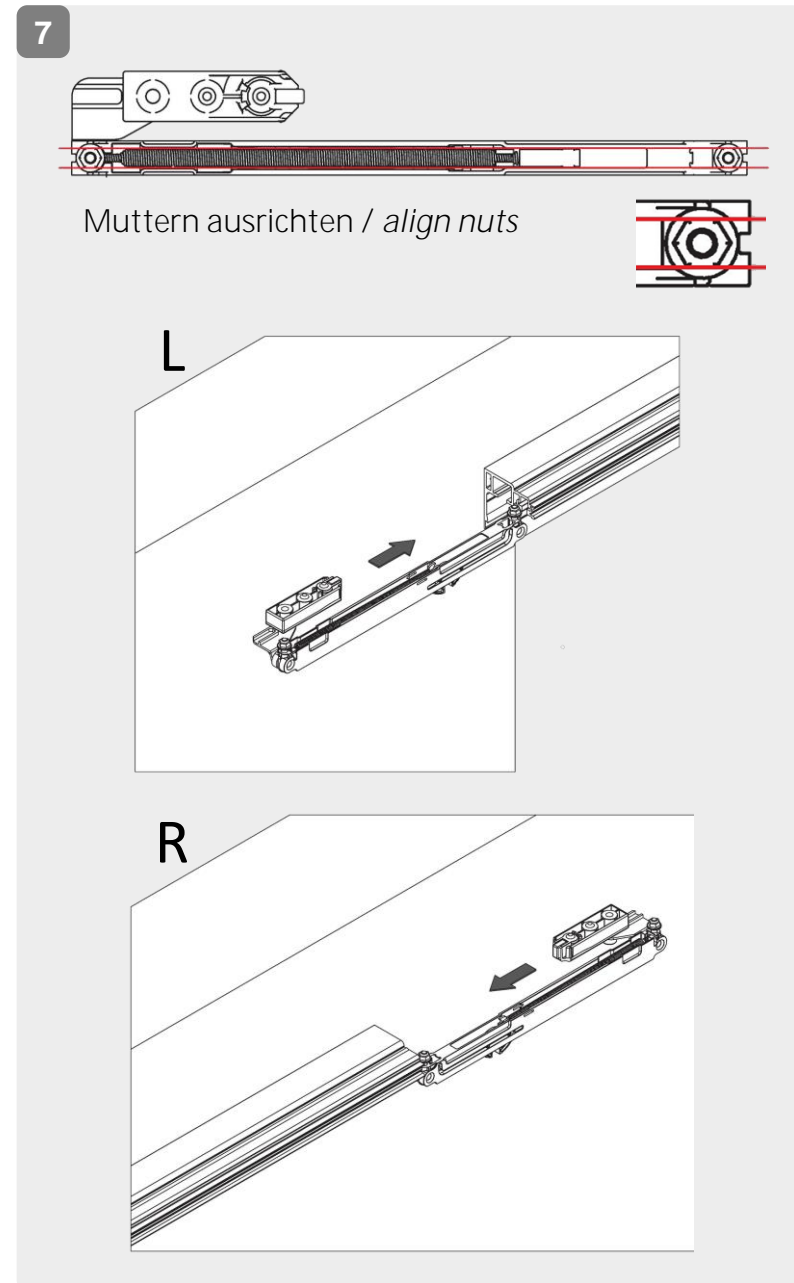

8

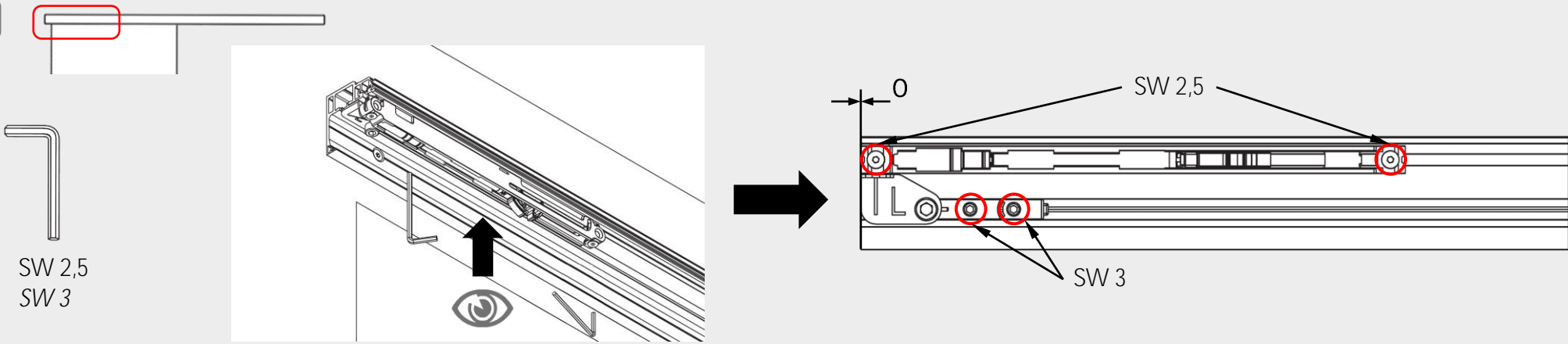

9a

Glastür / glass door

1

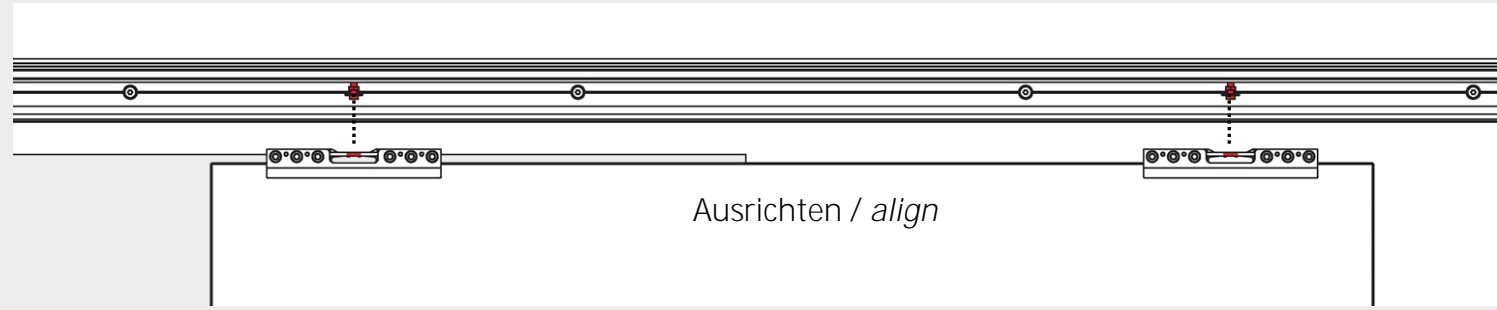

2

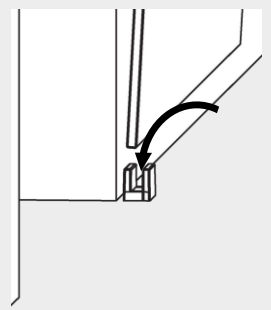

3

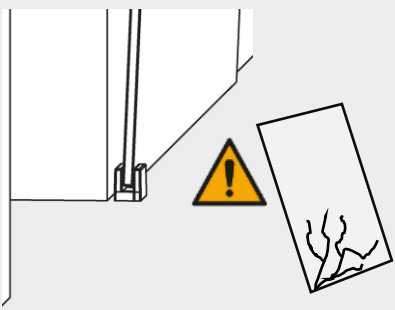

4

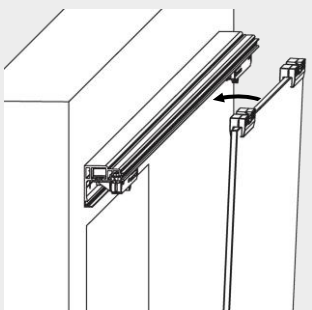

5

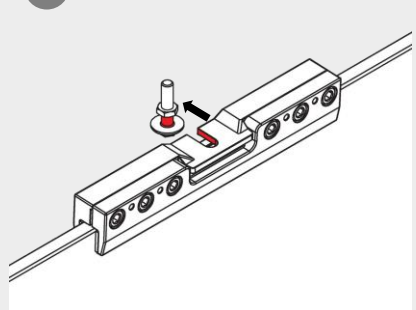

6

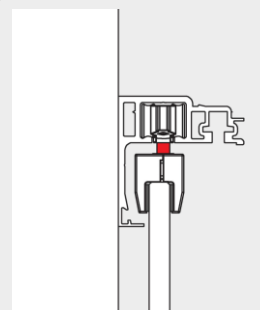

9b Holztür / wooden door

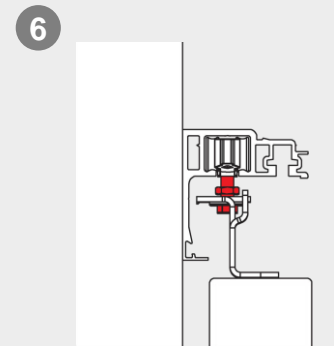
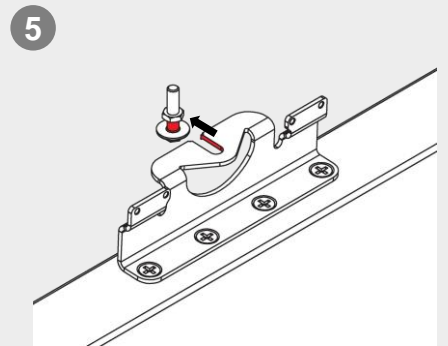
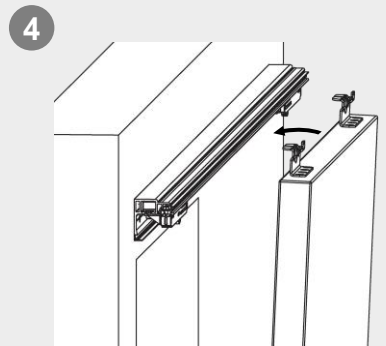
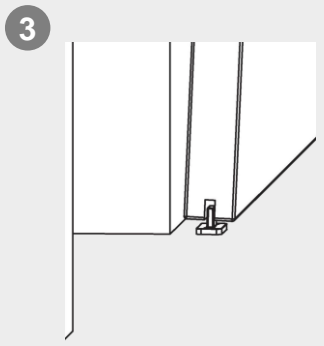
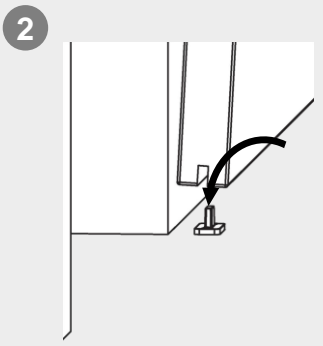
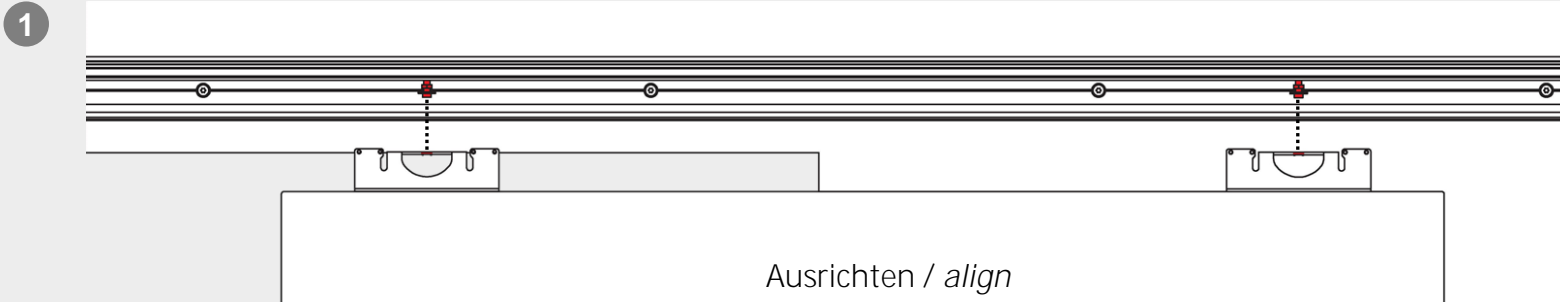

10 Höheneinstellung / height adjustment

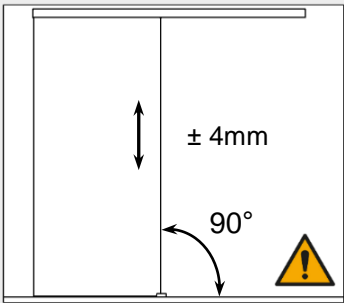

SW 7
SW 8

Glastür /
glass door

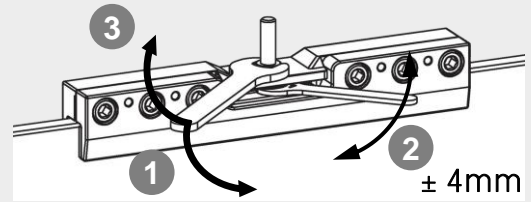

Holztür /
wooden door

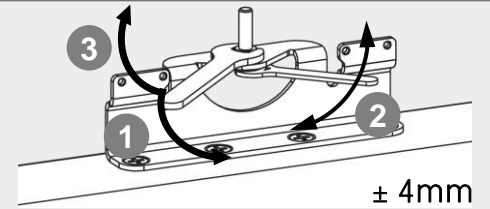

- 1 Mutter lösen /
loosen the nut
- 2 Höhe einstellen /
adjust height
- 3 Mutter anziehen /
tighten the nut

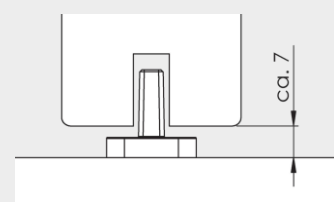
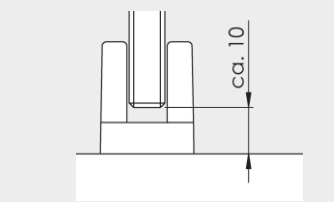

11

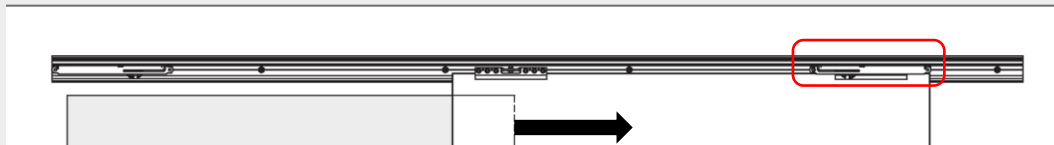

Ggf. Griffstangen/Griffmuscheln innen berücksichtigen und Endposition der Tür entsprechend wählen!
 If applicable, keep pull handles/finger pulls inside in mind and choose end position of door accordingly.

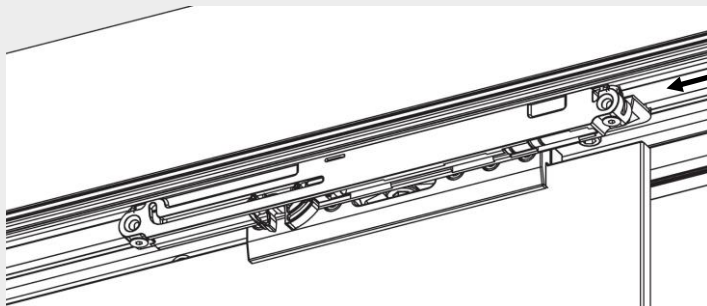

Stopper mit Softeinzug-Einheit gegen Laufwagen drücken /
 press Stopper with softclosing unit against carriage

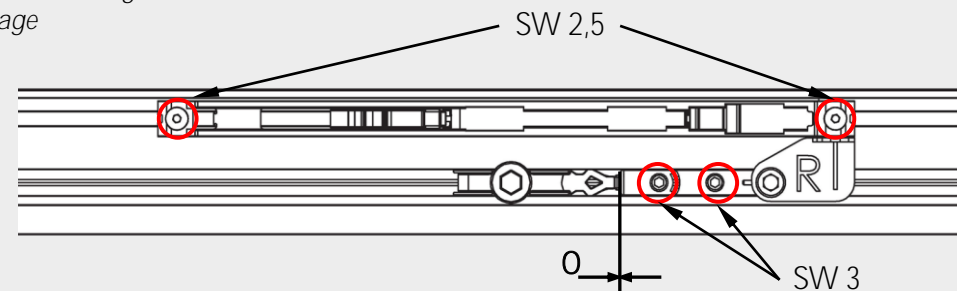
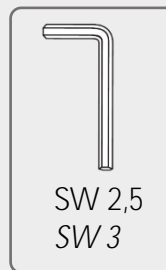

12

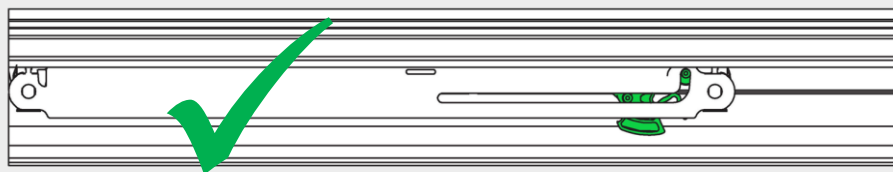
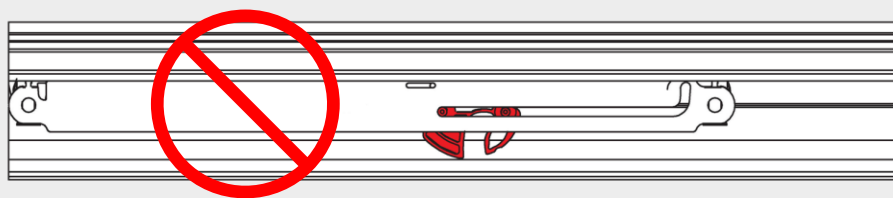

Falls nötig, Softeinzug spannen / if necessary, tension the softclose

13

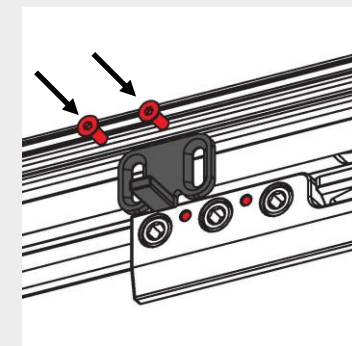
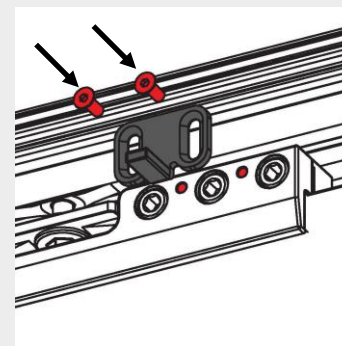
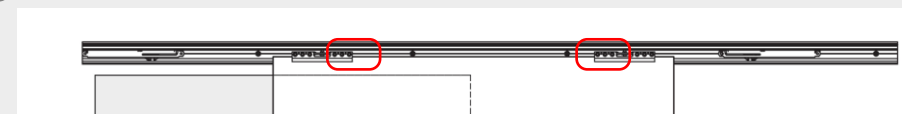

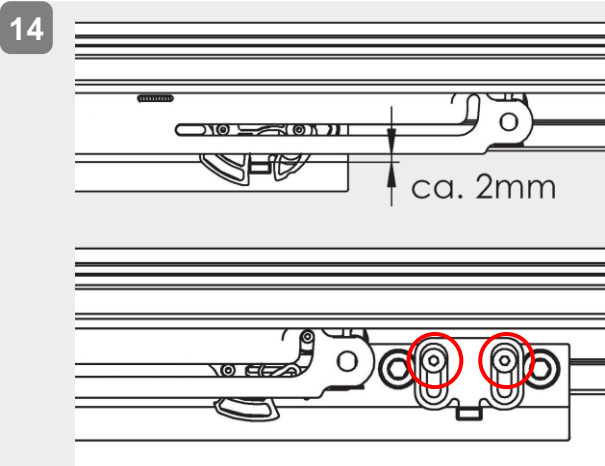

Falls nötig, anpassen /
adjust if necessary

ca. 2mm

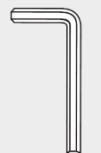

SW 2

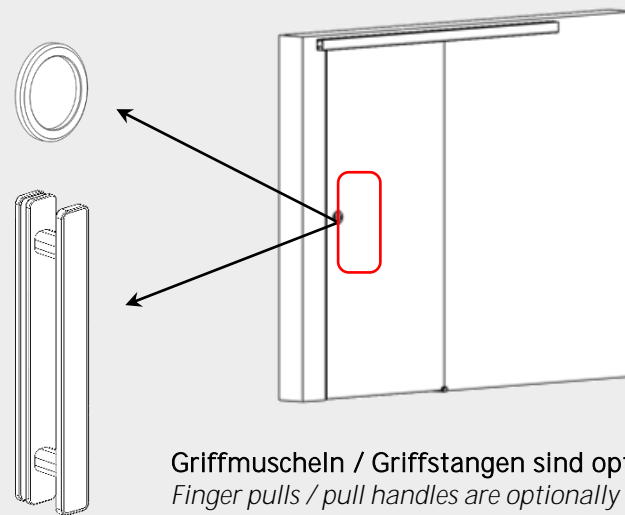
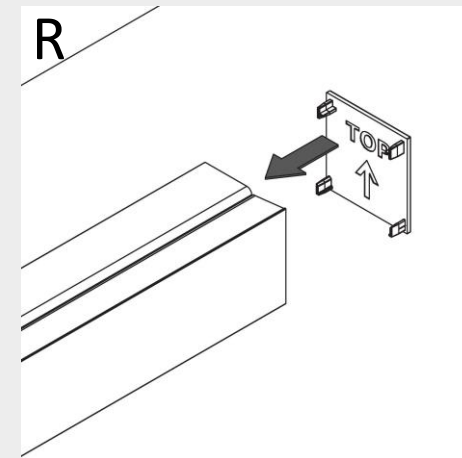
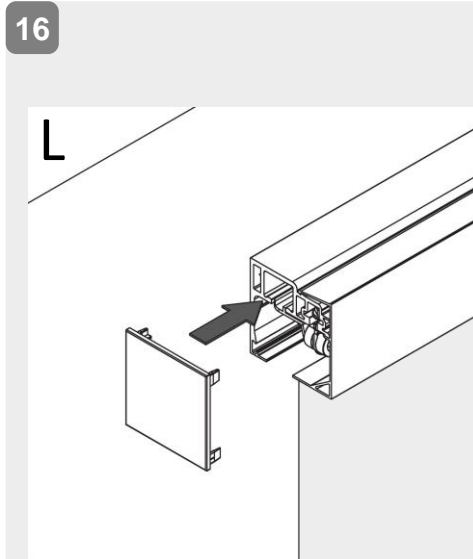
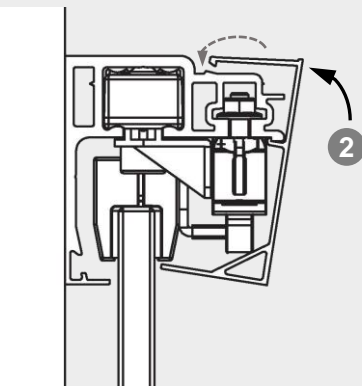
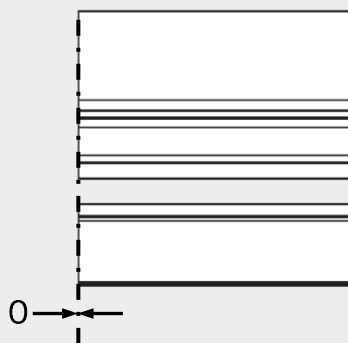
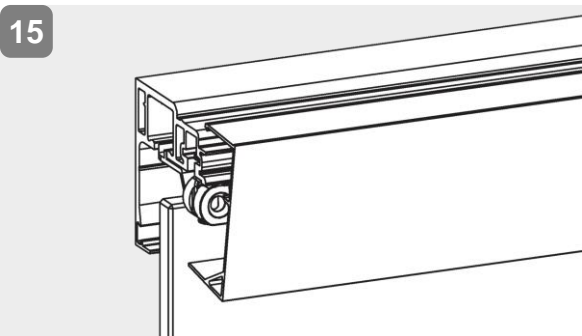

Griffmuscheln / Griffstangen sind optional erhältlich.
Finger pulls / pull handles are optionally available.